

## MAMIYA Interface Plate

To use the KODAK PROFESSIONAL DCS Pro Back or DCS Pro Back Plus (Pro Back/Pro Back Plus) with the MAMIYA RZ67 PRO II camera body (MAMIYA camera body), you must first attach the MAMIYA Interface Plate to the camera body.

1. Insert the four studs on the MAMIYA camera body into the four holes on the MAMIYA Interface Plate.

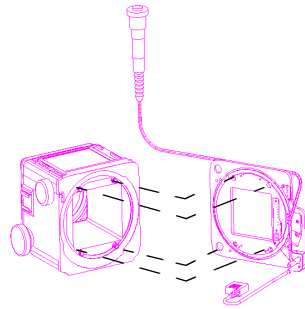

2. Slide the Lock handle downward to secure the plate to the camera body.

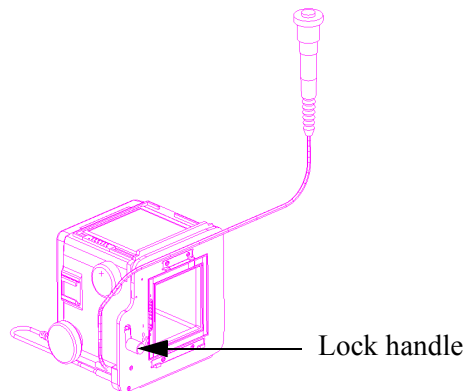

3. Turn the lever on the Cable Release plug to O. (Refer to the picture on page 3.) Insert the plug into the auxiliary release jack on the front of the RZ67, then turn the lever to L to lock the plug. (When removing the cable, turn the lever from L to O and pull the plug out.)

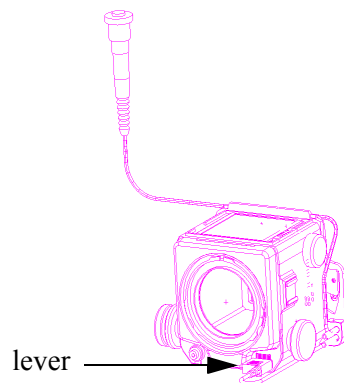

4. Attach the Pro Back/Pro Back Plus to the MAMIYA Interface Plate as described in the DCS Pro Back or DCS Pro Back Plus User's Manual.
5. Once the Pro Back/Pro Back Plus is attached, lock the Shutter Release on the camera body by rotating the Shutter Release lock as described in your RZ67 PRO II instruction manual. Use the Release button on the Capture cable to capture images. (The Shutter Release on the camera body will not capture digital images.)

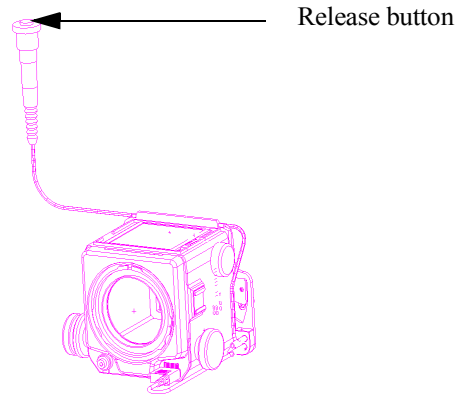

6. On the side of the camera body, set the R-M lever to M. The camera body does not respond to Pro Back/Pro Back Plus shutter release commands if the R-M lever is not in the M position.

### **Lens Sync Error**

If the Pro Back/Pro Back Plus issues a shutter release command and a lens shutter opening is not detected, the LCD displays the error message "Lens error: No sync detected!". If this error message appears when using your MAMIYA RZ67 PRO II, check for the following:

- The Lens Sync Cable is not connected between the MAMIYA lens Flash Sync Terminal and the Pro Back/Pro Back Plus's Lens Sync Cable jack.
- The MAMIYA Interface Plate's Cable Release is not plugged into the RZ67 PRO II camera body's auxiliary release jack. See step 3 on the previous page.
- The MAMIYA Interface Plate's Release button does not have its two white dots aligned. See "Electromagnetic Cable Release" on the next page.
- The MAMIYA RZ67 PRO II camera body has not been wound. Push the Cocking Lever all the way down.
- The MAMIYA RZ67 PRO II camera body R-M lever is not in the M position. See step 6 above.
- The MAMIYA RZ67 PRO II camera body's Shutter Speed dial is at the AEF setting and an AE viewfinder is not installed, or the dial is at the RBL setting and an RB lens is not installed.
- The Shutter Release collar is in the Emergency Shutter Operation position. Lock the Shutter Release Button as described in step 5 above.

## Electromagnetic Cable Release

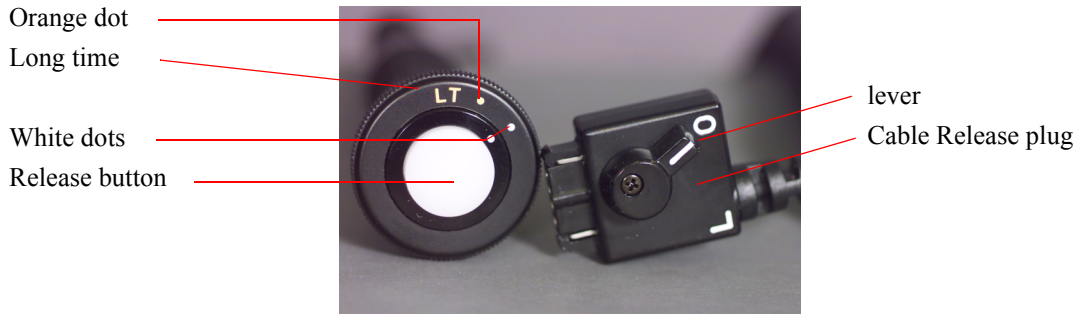

### Release Button

The Release button is a two-step position button. Each position provides a different function.

- Lightly press the Release button halfway down to collect photometric data.
- Press the button fully down to perform a shutter release.

When the two white dots are aligned, the ring is in the correct position for metering and shutter release.

When taking long time (LT) exposures in Bulb mode, lock the Release button by turning the outer ring clockwise and aligning the orange dot with the white dot. The Shutter release locks. To disengage a locked Shutter release, turn the ring counterclockwise and return the orange dot to its original position.

NOTE: We do not recommend Pro Back/Pro Back Plus exposures that exceed 1/4 second shutter times.